

Surname	Centre Number	Candidate Number
Other Names		0



GCSE

4370/05



S15-4370-05

**MATHEMATICS – LINEAR
PAPER 1
HIGHER TIER**

A.M. THURSDAY, 21 May 2015

2 hours

**CALCULATORS ARE
NOT TO BE USED
FOR THIS PAPER**

ADDITIONAL MATERIALS

A ruler, a protractor and a pair of compasses may be required.

INSTRUCTIONS TO CANDIDATES

Use black ink or black ball-point pen. Do not use gel pen or correction fluid.

Write your name, centre number and candidate number in the spaces at the top of this page.

Answer **all** the questions in the spaces provided.

If you run out of space, use the continuation page at the back of the booklet, taking care to number the question(s) correctly.

Take π as 3.14.

INFORMATION FOR CANDIDATES

You should give details of your method of solution when appropriate.

Unless stated, diagrams are not drawn to scale.

Scale drawing solutions will not be acceptable where you are asked to calculate.

The number of marks is given in brackets at the end of each question or part-question.

You are reminded that assessment will take into account the quality of written communication (including mathematical communication) used in your answer to question 5.

For Examiner's use only		
Question	Maximum Mark	Mark Awarded
1.	5	
2.	5	
3.	6	
4.	2	
5.	7	
6.	4	
7.	3	
8.	2	
9.	6	
10.	3	
11.	3	
12.	7	
13.	7	
14.	5	
15.	8	
16.	8	
17.	5	
18.	8	
19.	6	
Total	100	



MAY1543700501

Formula List

$$\text{Area of trapezium} = \frac{1}{2}(a + b)h$$

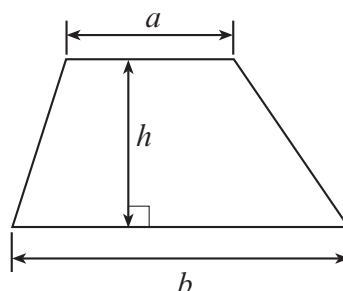

$$\text{Volume of prism} = \text{area of cross-section} \times \text{length}$$

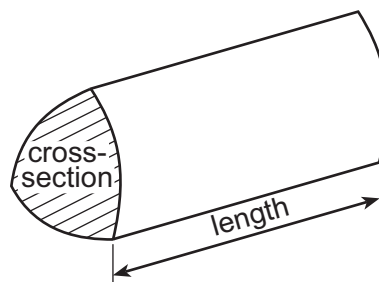

$$\text{Volume of sphere} = \frac{4}{3}\pi r^3$$

$$\text{Surface area of sphere} = 4\pi r^2$$

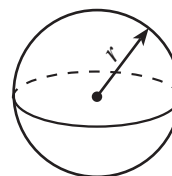

$$\text{Volume of cone} = \frac{1}{3}\pi r^2 h$$

$$\text{Curved surface area of cone} = \pi r l$$

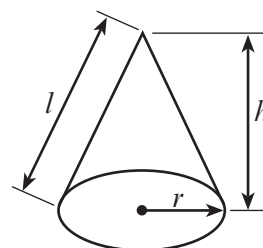

In any triangle ABC

$$\text{Sine rule} \quad \frac{a}{\sin A} = \frac{b}{\sin B} = \frac{c}{\sin C}$$

$$\text{Cosine rule} \quad a^2 = b^2 + c^2 - 2bc \cos A$$

$$\text{Area of triangle} = \frac{1}{2}ab \sin C$$

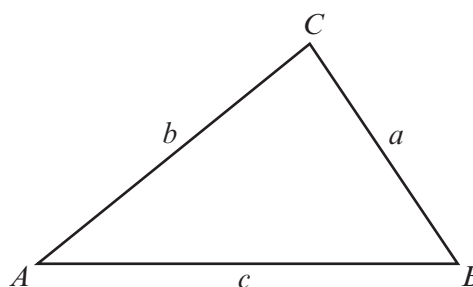

The Quadratic Equation

The solutions of $ax^2 + bx + c = 0$

where $a \neq 0$ are given by

$$x = \frac{-b \pm \sqrt{b^2 - 4ac}}{2a}$$



1. Use the exchange rate **£1 = 1.52 US dollars** to answer the following questions.

(a) Gareth exchanges £300 into US dollars.
How many US dollars will he receive?

[2]

.....

.....

.....

.....

.....

.....

.....

.....

.....

.....

(b) Adrienne wants to exchange 585 US dollars into pounds (£).
Estimate how many pounds Adrienne is likely to receive.
You must show your working.

[3]

.....

.....

.....

.....

.....

.....

.....

.....

.....

.....

.....

.....

.....

.....

.....

.....

.....

.....

.....

.....

.....

.....

4370
050003



2. The map below shows a route from Edinburgh to Dundee.

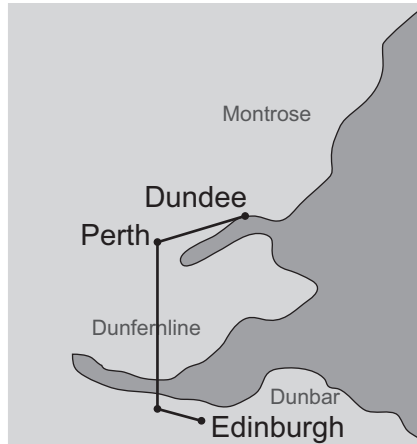

The route from Edinburgh to Dundee is approximately 4 cm on the map.
The actual journey is approximately 100 kilometres.

(a) Calculate the scale of the map, giving your answer in the form **1** : [2]

.....

.....

.....

.....

.....

.....

(b) The journey from Edinburgh to Dundee takes 2 hours 30 minutes by car.
Calculate the average speed of this journey.
Give your answer in kilometres per hour. [3]

.....

.....

.....

.....

.....



4. The bearing of Ryeton from Cwm is 235° .
Write down the bearing of Cwm from Ryeton.

[2]

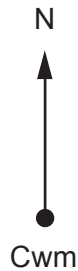

.....

.....

.....

.....

5. *You will be assessed on the quality of your written communication in this question.*

In a factory there are two machines.
Machine A makes plastic spoons and Machine B makes plastic forks.
Both machines work at a steady rate.

Machine A makes **180** plastic spoons per hour.



Machine B makes **240** plastic forks per hour.



Both machines start their production on a Monday morning at 9 a.m.
Both machines are stopped for maintenance after 450 spoons have been produced.
Calculate

- the time at which the machines were stopped for maintenance
- the number of forks produced between 9 a.m. and the time the machines were stopped for maintenance.

[7]

.....

.....



Examiner
only

A large rectangular area containing horizontal dotted lines for writing.

4370
050007



6. (a) Rotate triangle A through 90° anticlockwise about the point $(2, -1)$. [2]

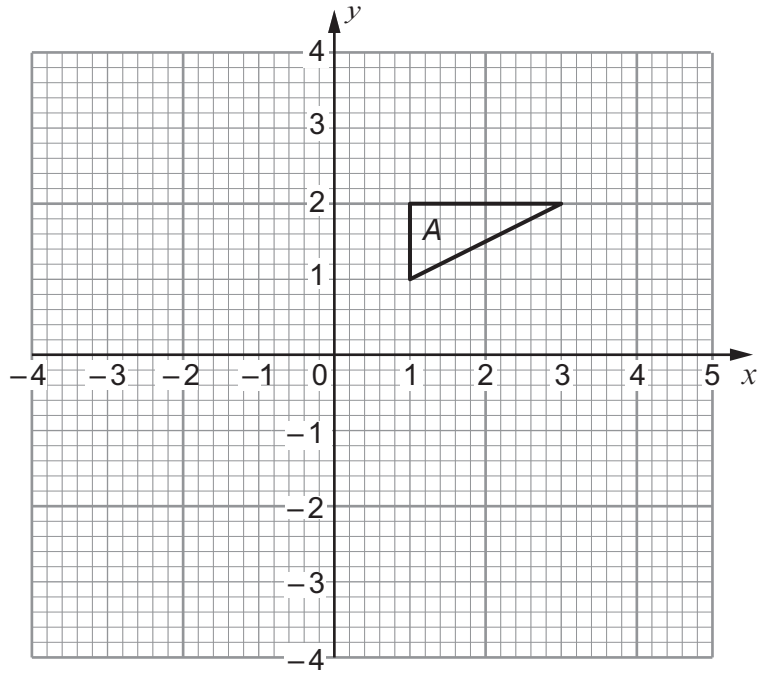

- (b) Using the point B as the centre, enlarge the quadrilateral by a scale factor of $\frac{1}{2}$. [2]

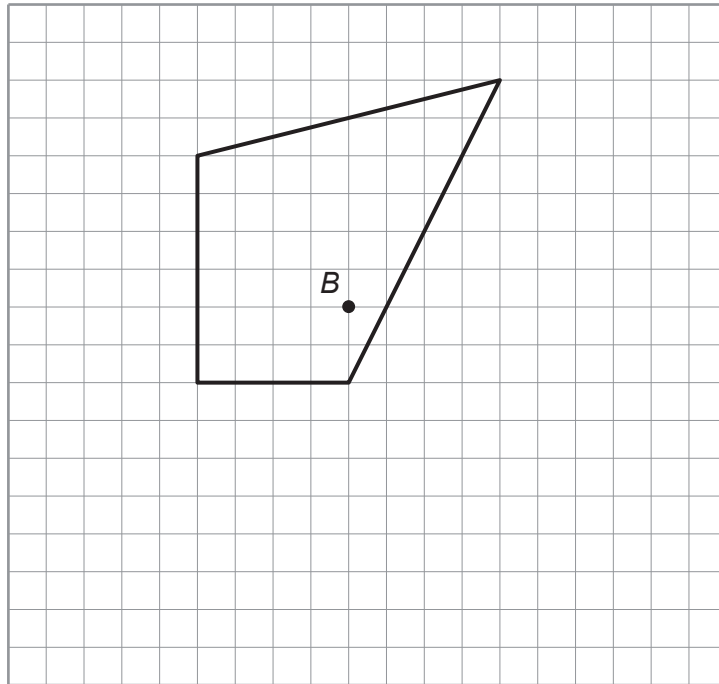

7. The diagram below shows part of a regular polygon.



Diagram not drawn to scale

How many sides does this regular polygon have altogether?

[3]

.....

.....

.....

.....

.....

.....

.....

.....

8. Megan has a fair 6-sided dice.



She throws the dice twice.
Calculate the probability that she throws a 4 both times.

[2]

.....

.....

.....

.....

.....

.....

.....



9. (a) Find the integer that satisfies the equation $x^3 - 2x = 21$.
You must show all your working.

[2]

.....

.....

.....

.....

.....

- (b) Solve $y^2 = 49$.
You must write down all possible solutions.

[2]

.....

.....

- (c) Expand $x^3(3x - 5)$.

[2]

.....

.....

10. A mixed number is a whole number with a fraction.

$4\frac{3}{4}$ and $2\frac{3}{8}$ are mixed numbers.

Evaluate $4\frac{3}{4} + 2\frac{3}{8}$.

Express your answer as a mixed number in its simplest form.

[3]

.....

.....

.....

.....

.....

.....

.....

.....

.....

.....



11. A hollow cylinder is made with an internal radius of 4 cm and an internal height of 10 cm.

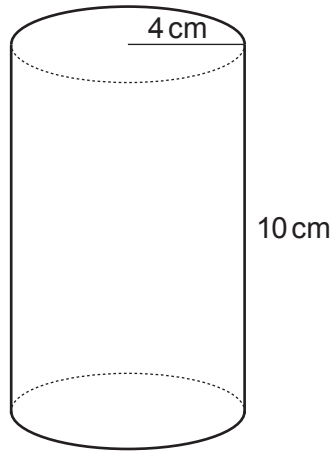

Diagram not drawn to scale

Carwyn says

'This cylinder holds approximately 5 litres of liquid.'

By estimating π as 3, show whether Carwyn is correct or not.

You must show your working and give a reason for your answer.

[3]

.....

.....

.....

.....

.....

.....

.....

.....

.....

.....

.....

.....

.....

.....

.....

.....

.....

.....

.....

.....

.....

.....

.....

.....



12. Dewi writes the first 6 numbers of a sequence on a notepad.

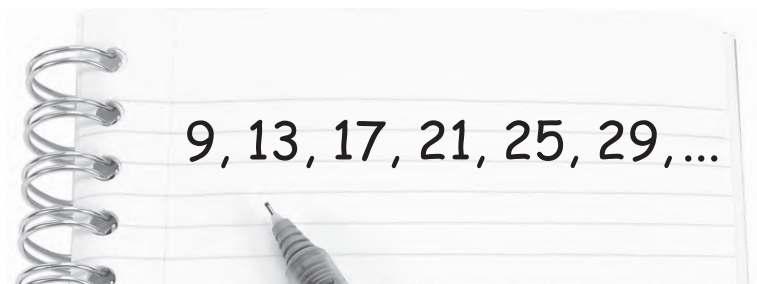

(a) (i) Write down the n th term of Dewi's sequence. [2]

.....

.....

(ii) Carys says that 149 is in Dewi's sequence.
Is Carys correct?
You must explain your answer. [1]

.....

.....

.....

.....

.....

.....

(b) Val works for WindPane, a company that makes rectangular windows using small panes of glass.
All the small panes of glass are the same size.

Val has drawn patterns of windows and the panes of glass, as shown below.

Pattern 1

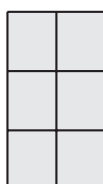

Pattern 2

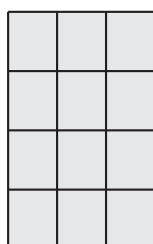

Pattern 3

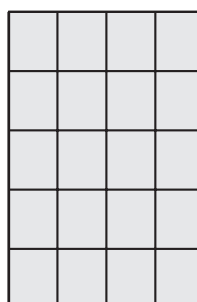

Pattern 4

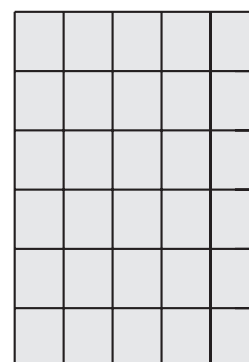

- (i) Imran says that there would be 110 panes in Pattern 8.
Is Imran correct?
You must explain your answer.

[2]

.....

.....

.....

.....

.....

.....

- (ii) Val says that Pattern n contains $n^2 + 3n + 2$ panes of glass.
Is Val correct?
You must show your working and justify your answer.

[2]

.....

.....

.....

.....

.....

.....

.....

.....

.....

.....

.....

.....

.....

.....

.....

.....

.....

.....



13. The grouped frequency table shows information about the weekly wages of 160 office workers.

Weekly wage, £ x	Frequency
$100 < x \leq 200$	10
$200 < x \leq 300$	22
$300 < x \leq 400$	46
$400 < x \leq 500$	54
$500 < x \leq 600$	18
$600 < x \leq 700$	10

(a) Complete the following cumulative frequency table. [1]

Weekly wage, £ x	Cumulative frequency
$x \leq 100$	0
$x \leq 200$	10
$x \leq 300$	
$x \leq 400$	
$x \leq 500$	
$x \leq 600$	
$x \leq 700$	

(b) Use the graph paper opposite to draw a cumulative frequency diagram for the weekly wages of the 160 office workers. [3]

(c) Calculate an estimate for the interquartile range. [2]

.....

.....

.....

(d) Estimate the number of workers with a weekly wage of more than £520. [1]

.....



Cumulative frequency

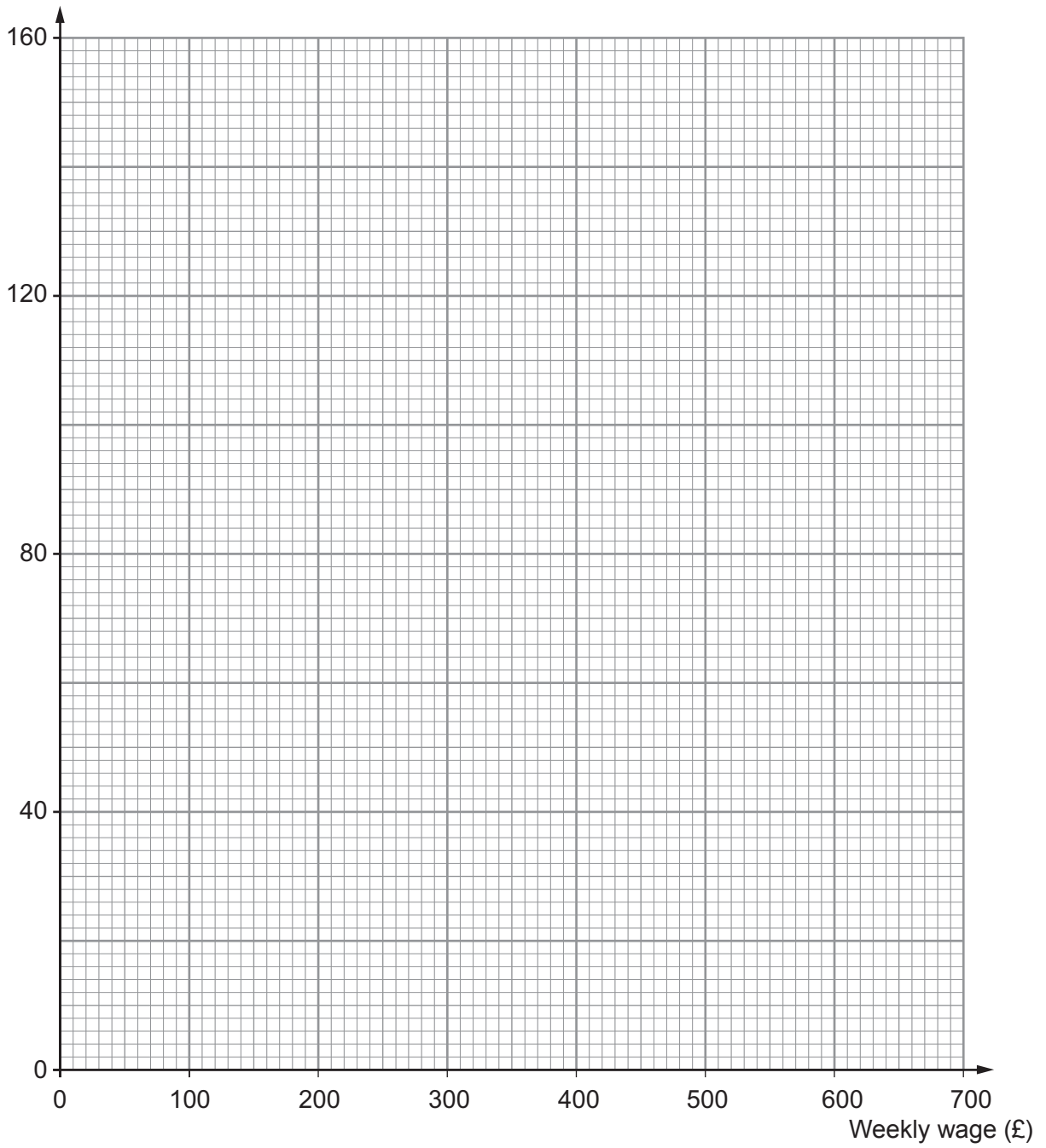

14. (a) Solve $x^2 + 2x - 15 = 0$.

[3]

.....

.....

.....

.....

.....

(b) Simplify $3a^3 b^5 \times 4a^6 b$.

[2]

.....

.....

.....

.....



16. The histogram illustrates the lengths of telephone calls made to a computer helpline during one Friday evening.

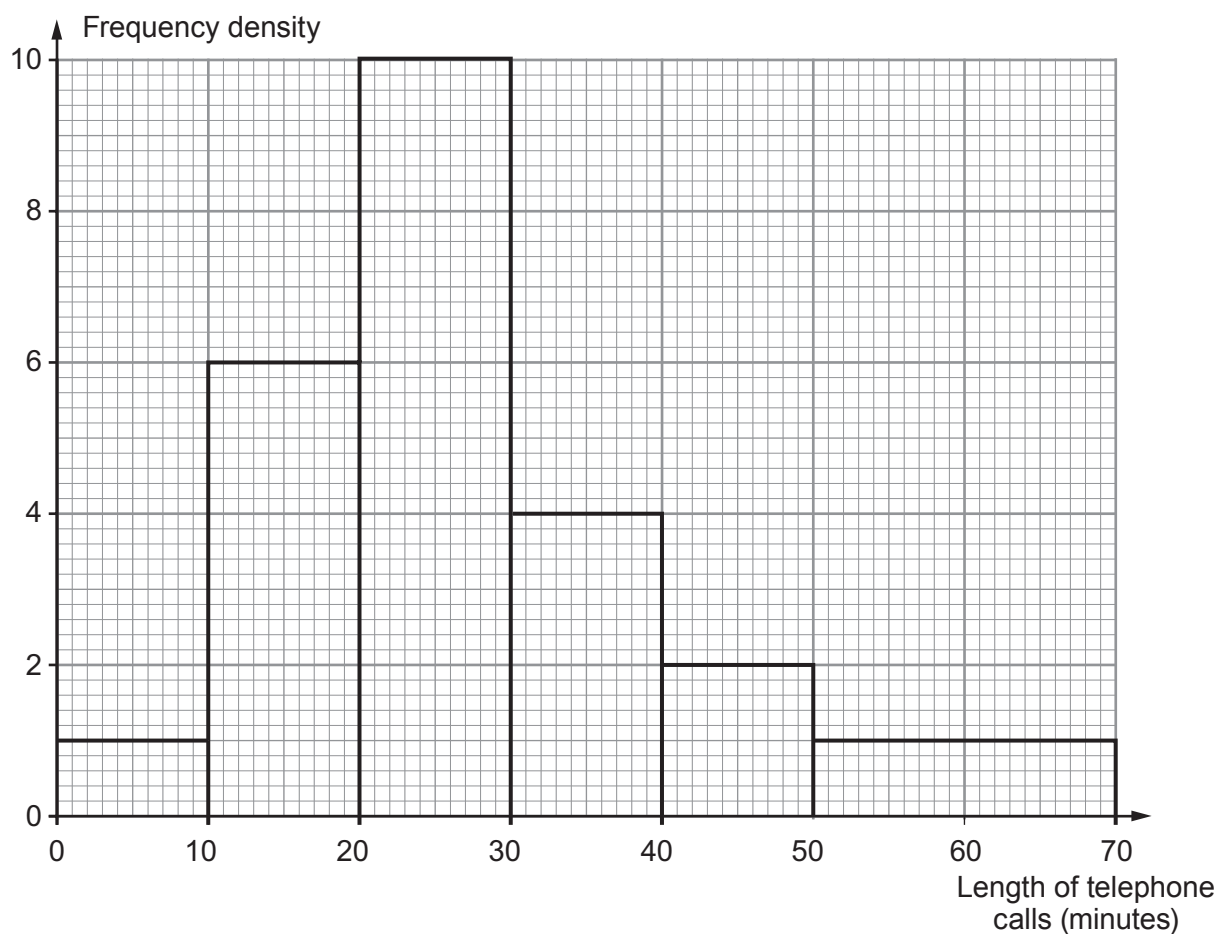

- (a) Calculate how many telephone calls were made to the computer helpline during the Friday evening. [3]

.....

.....

.....

.....

- (b) Calculate an estimate of the percentage of telephone calls that lasted longer than $\frac{3}{4}$ of an hour. [2]

.....

.....

.....

.....



- (c) Estimate the median length of a telephone call made to the computer helpline during the Friday evening.
Give your answer correct to 1 decimal place. [3]

.....

.....

.....

.....

.....

.....

17. (a) Express $0.3\dot{4}6$ as a fraction. [2]

.....

.....

.....

.....

.....

.....

- (b) Simplify $(7 - 5\sqrt{2})^2$ and state whether your answer is rational or irrational. [3]

.....

.....

.....

.....

.....

.....



18. A scientist records the velocity, v m/s, of a particle from time $t = 0$ to $t = 9$ seconds. His results are shown in the graph below.



- (a) Use the graph to estimate the acceleration of the particle at $t = 1.5$.
Give your answer to one decimal place. [3]

.....

.....

- (b) (i) Use the trapezium rule, with the ordinates $t = 0$, $t = 3$, $t = 6$ and $t = 9$ to estimate the distance the particle travelled during the experiment. [4]

.....

.....

.....

.....

.....

.....

.....

.....

.....

.....

- (ii) By considering the graph given, state how you would improve on the estimate for the distance the particle travelled during the experiment. [1]

.....

.....

.....



19. Twenty raffle tickets are sold.
The tickets sold are numbered from 1 to 20.
The raffle tickets are placed in a drum for a draw.
Two raffle tickets are selected at random, one ticket at a time, and not replaced in the drum.

(a) Find the probability that one of the tickets drawn is even and the other is odd. [3]

.....

.....

.....

.....

.....

.....

.....

.....

(b) Find the probability that at least one of the tickets drawn is odd. [3]

.....

.....

.....

.....

.....

.....

.....

.....

.....

END OF PAPER



BLANK PAGE

**PLEASE DO NOT WRITE
ON THIS PAGE**



BLANK PAGE

**PLEASE DO NOT WRITE
ON THIS PAGE**

